

# Farmpackers proposées par

**AVYAPY**

Official Distributor |

**SANOVO**  
TECHNOLOGY GROUP



# Farmpacker Series

SANOVO FARMPACKER 40, 70, 100,  
200



# SANOVO Farmpacker 40

14 400 œufs/h (40 caisses/h)



- Doseur avec contrôle de pression d'œufs
- Détection de présence alvéole
- Détection de convoyeur d'alvéoles plein
- Sécurité sur les capots
- Différents montages

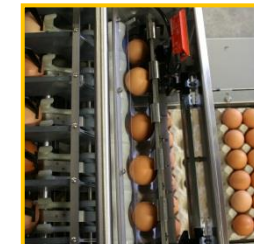

# SANOVO Farmpacker 40 – Différents aménagements

## Models

- SFP40 A1
- SFP40 A2
- SFP40 A3
- SFP40 A4

- SFP40 SXA1
- SFP40 SXA2
- SFP40 SXA3
- SFP40 SXA4

To be introduced C/UL models

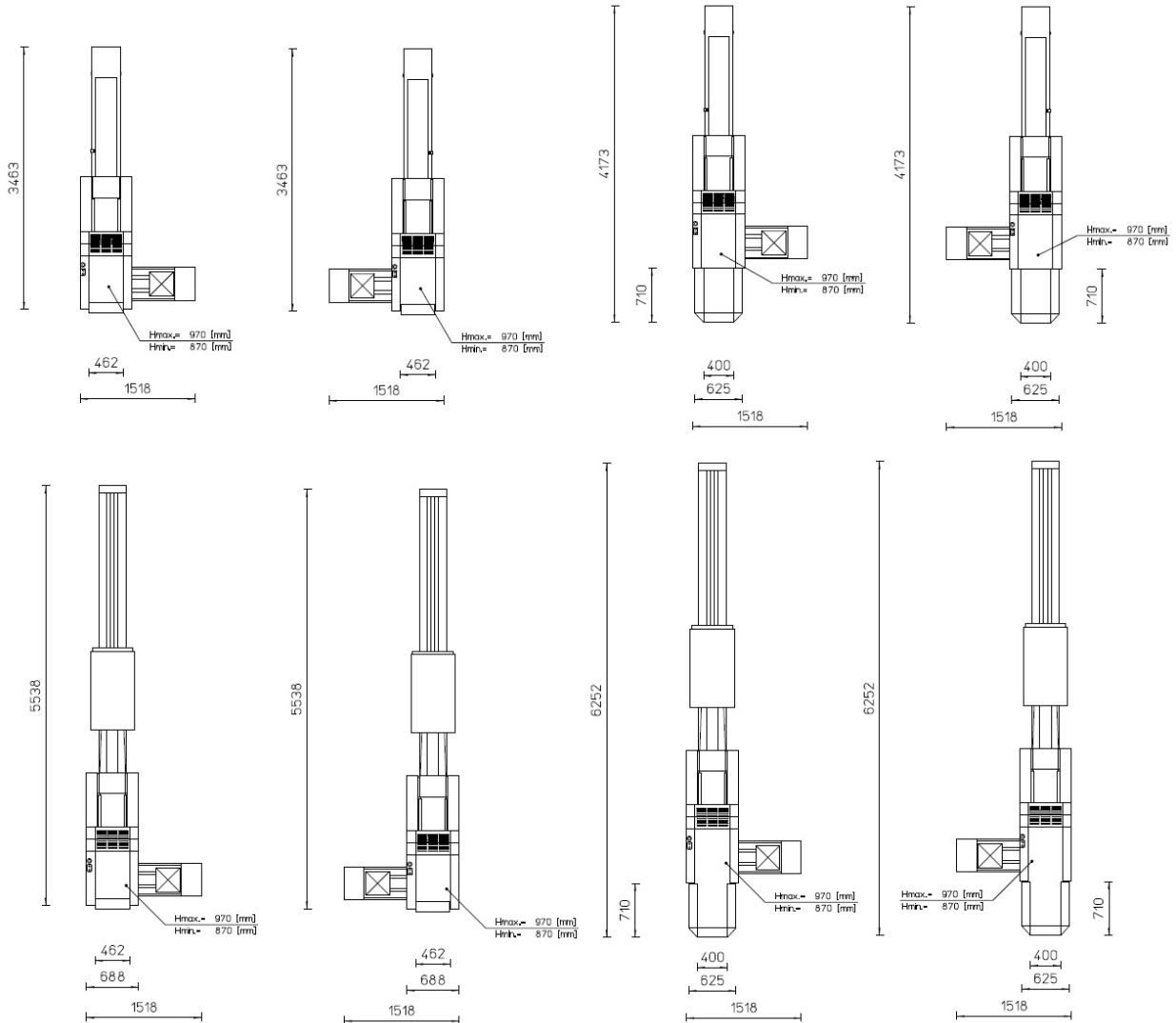

# SANOVO Farmpacker 40 – Différents aménagements

## Models

- SFP40 A1SX20
- SFP40 A2SX20
- SFP40 A3SX20
- SFP40 A4SX20

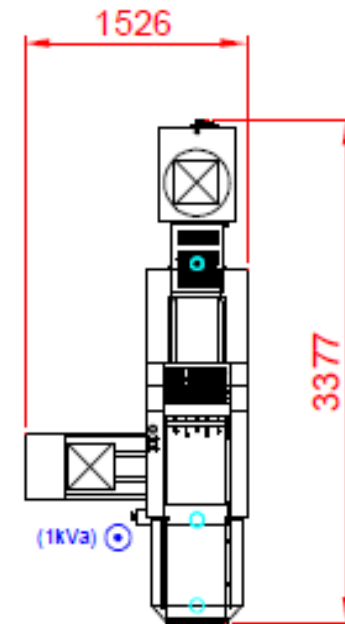
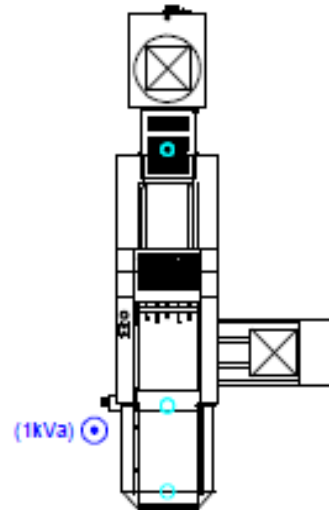
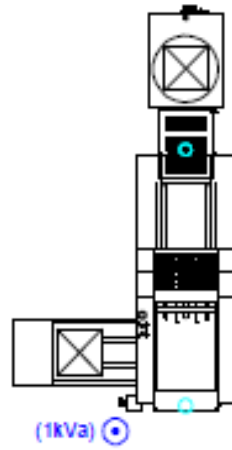
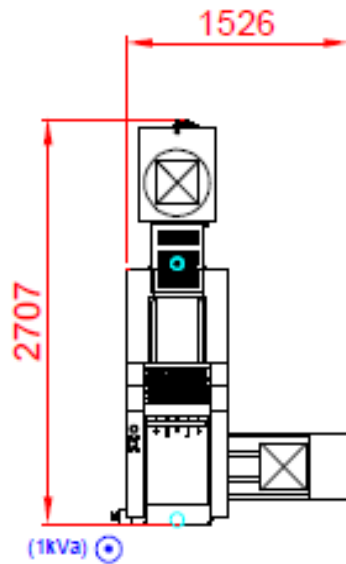

# SANOVO Farmpacker 40 – Le dépilleur d'alvéoles en ligne.

**NOUVEAUTÉ**

- Encombrement réduit en largeur.
- Idéal pour les petits espaces.

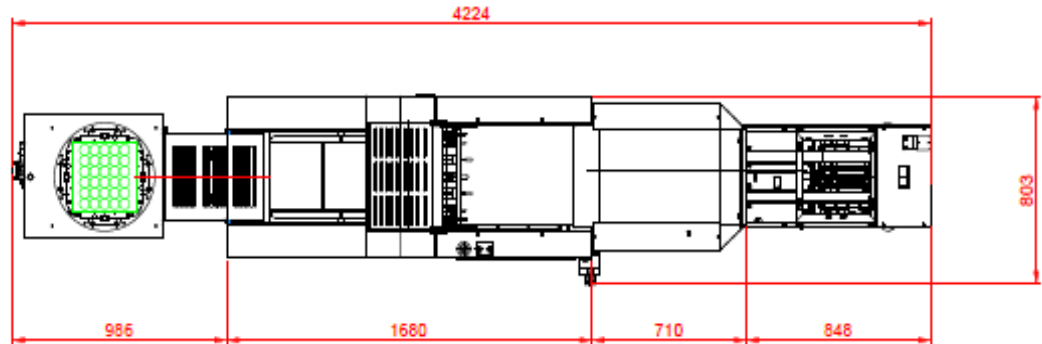
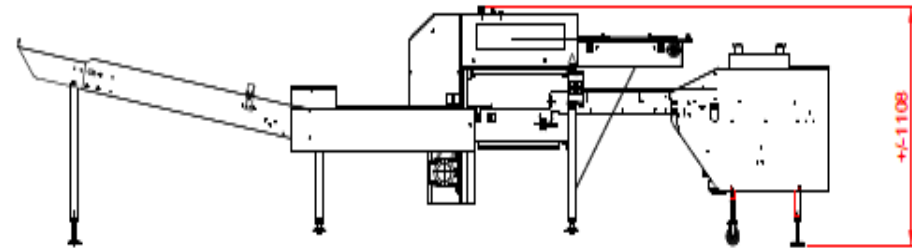
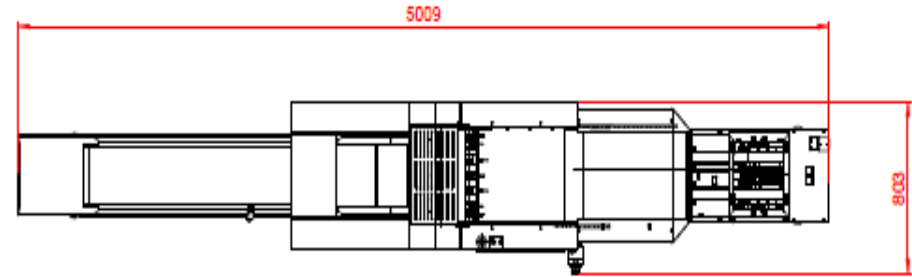

# SANOVO Farmpacker 40 – Différents aménagements

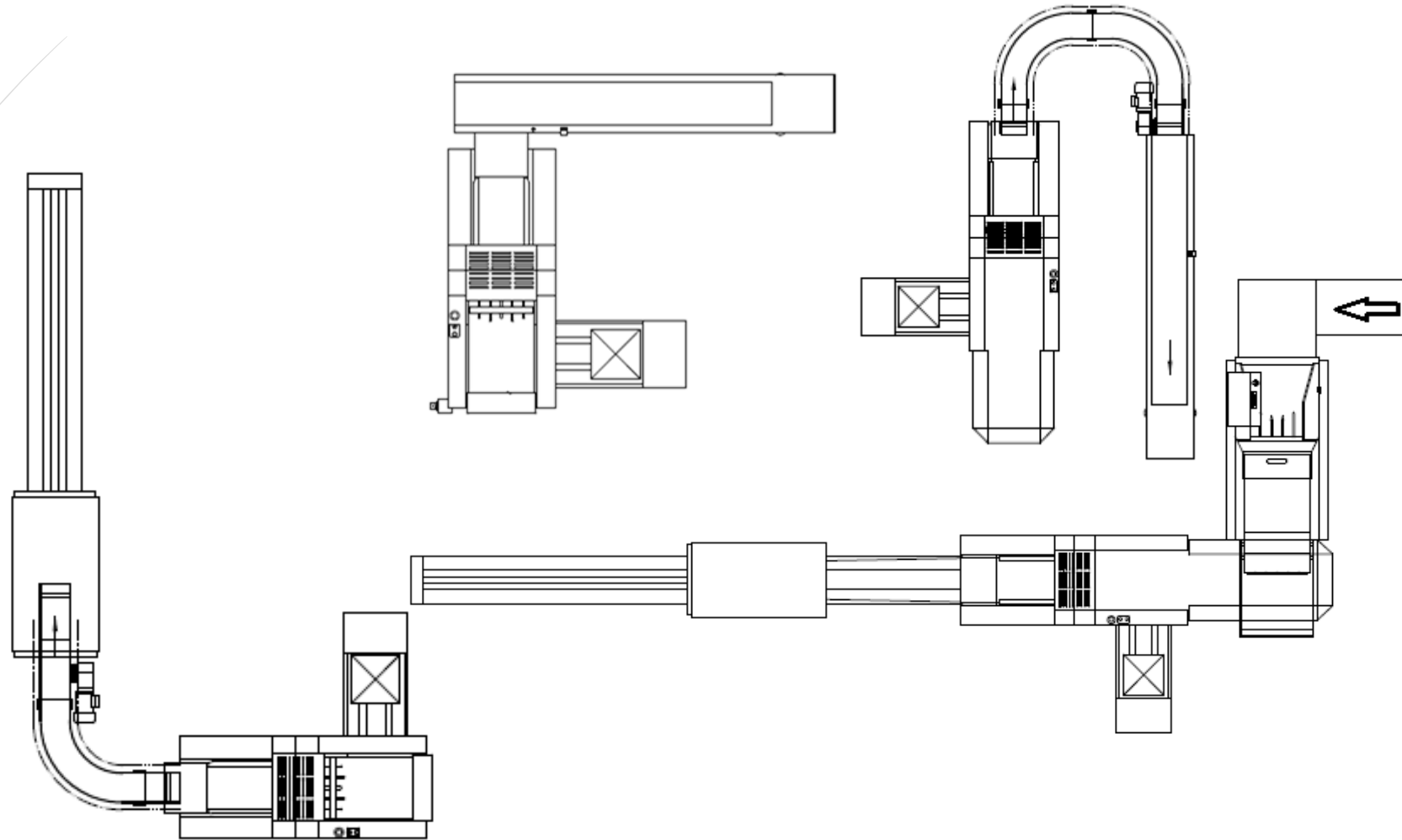
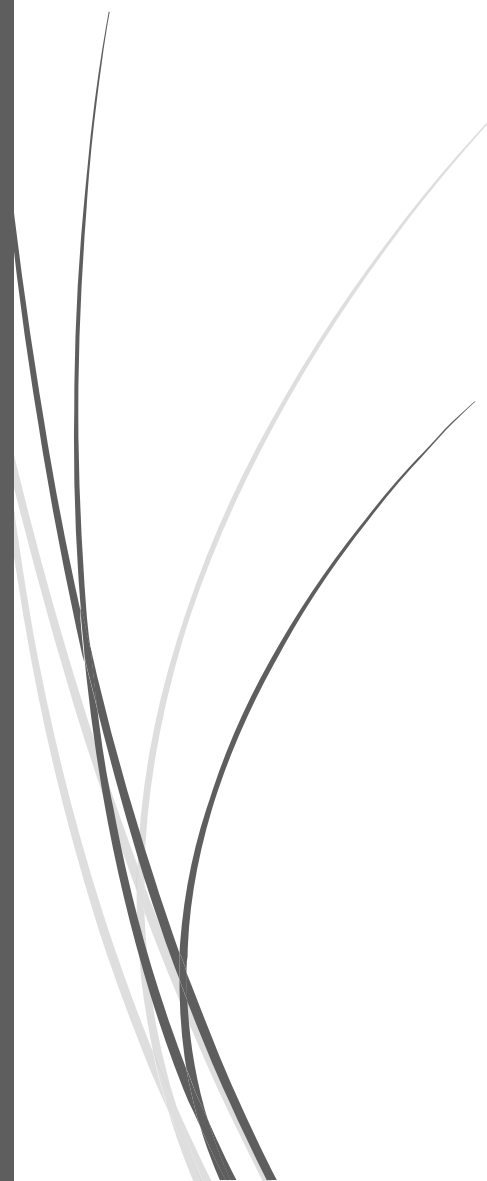



# SANOVO Farmpacker 70

25 200 Œufs/h (70 caisses/h)

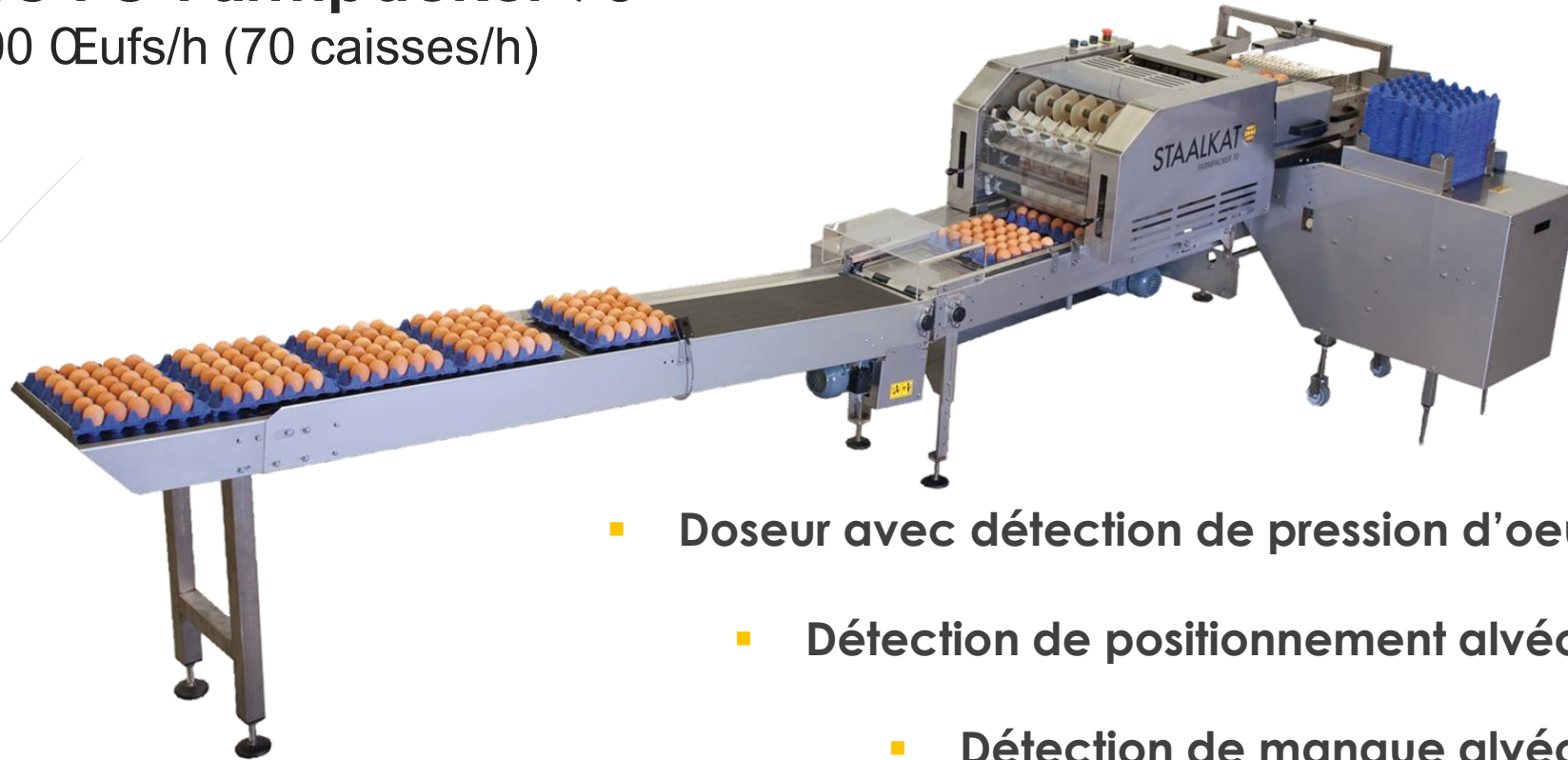

- Doseur avec détection de pression d'œufs
  - Détection de positionnement alvéole
    - Détection de manque alvéole
- Détection de convoyeur d'alvéole plein
  - Sécurité sur les capots

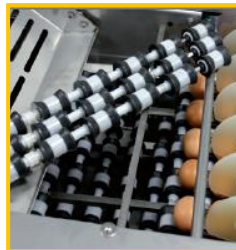



# SANOVO Farmpacker 70, Différents aménagements

## Models

- SFP70 A1
- SFP70 A2
- SFP70 A3
- SFP70 A4

- SFP70 SXA1
- SFP70 SXA2
- SFP70 SXA3
- SFP70 SXA4

To be introduced C/UL models

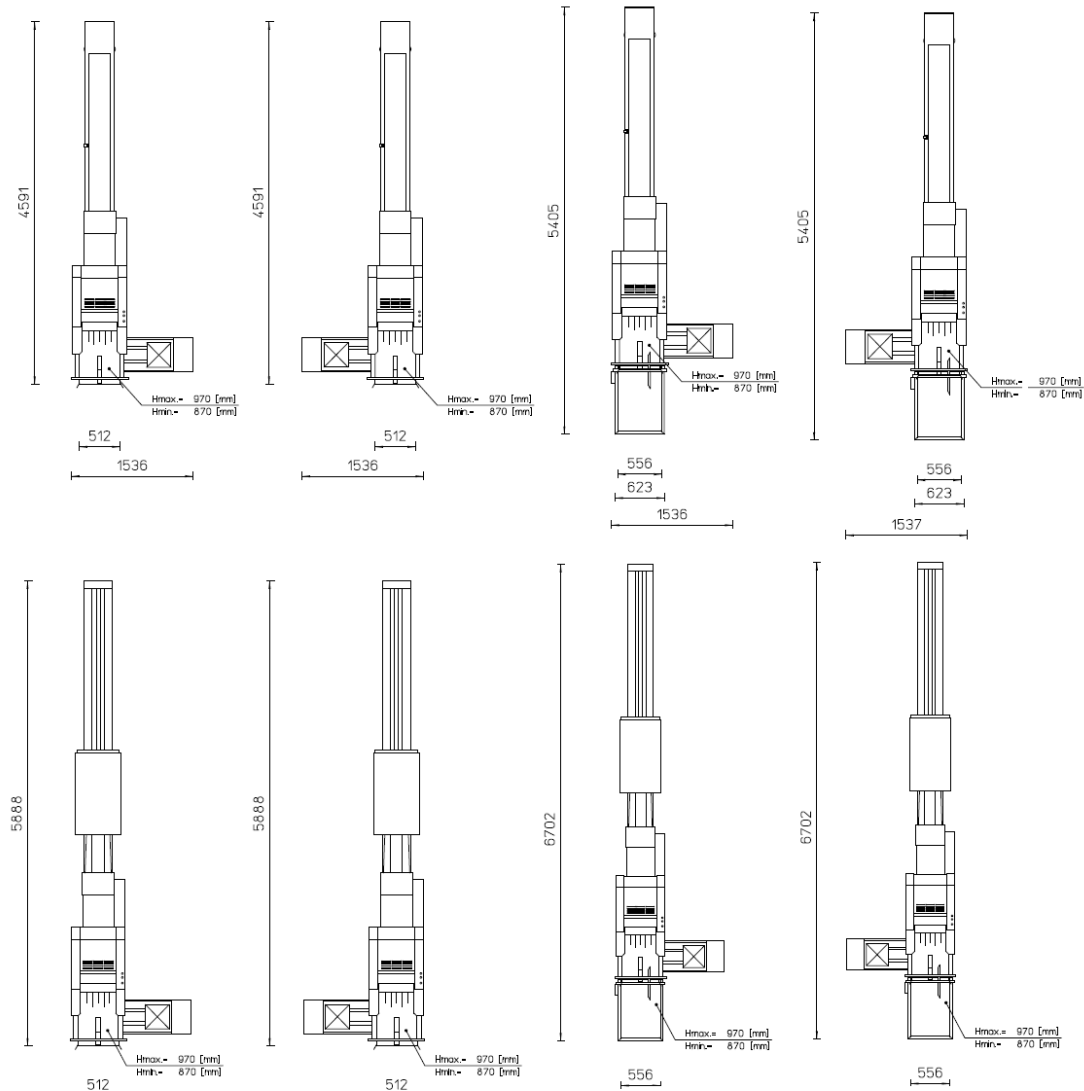

# SANOVO Farnpacker 70, différents aménagements

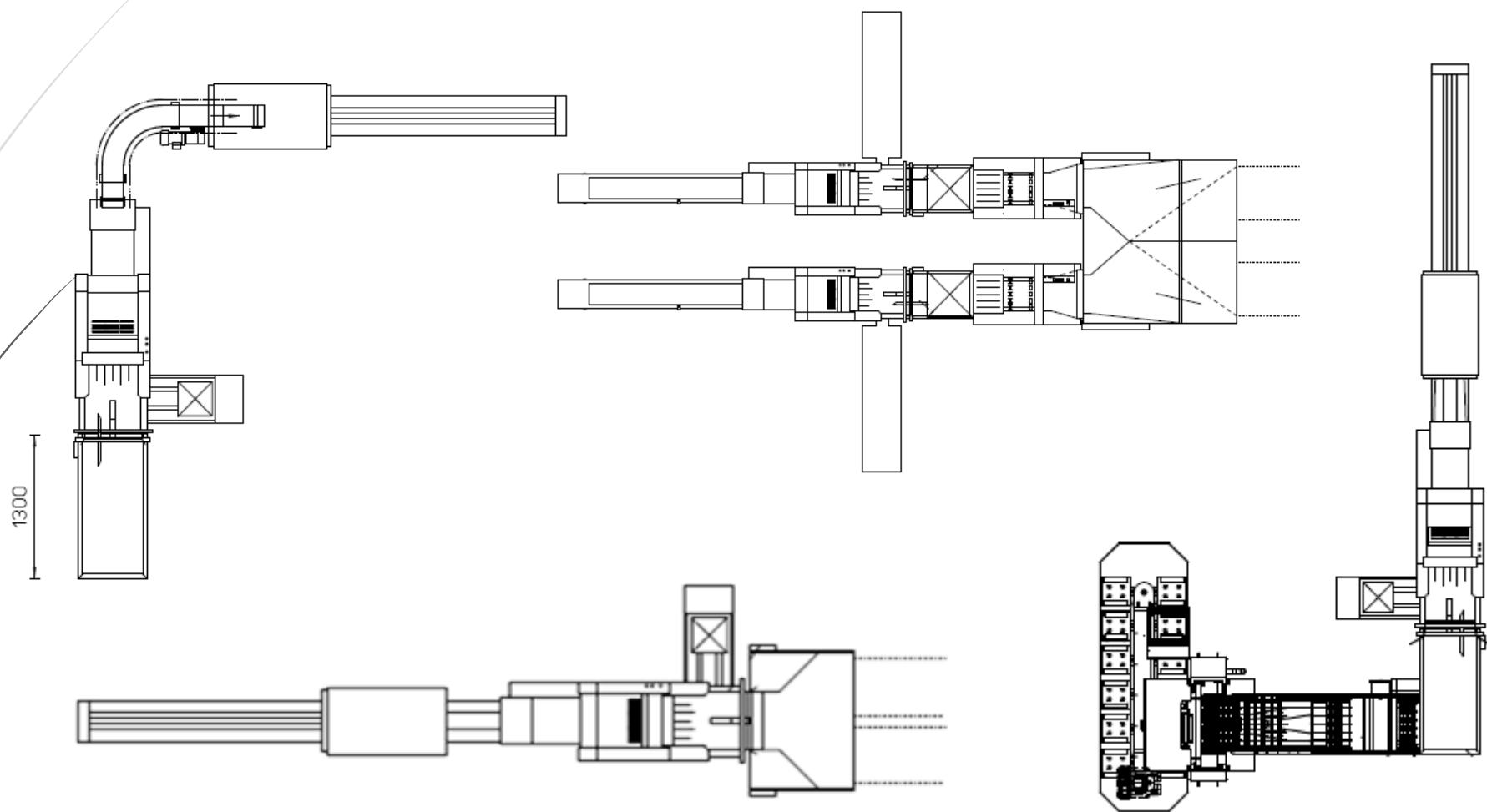

# SANOVO Farmpacker 100

36 000 Oeufs/h (100 caisses/h)

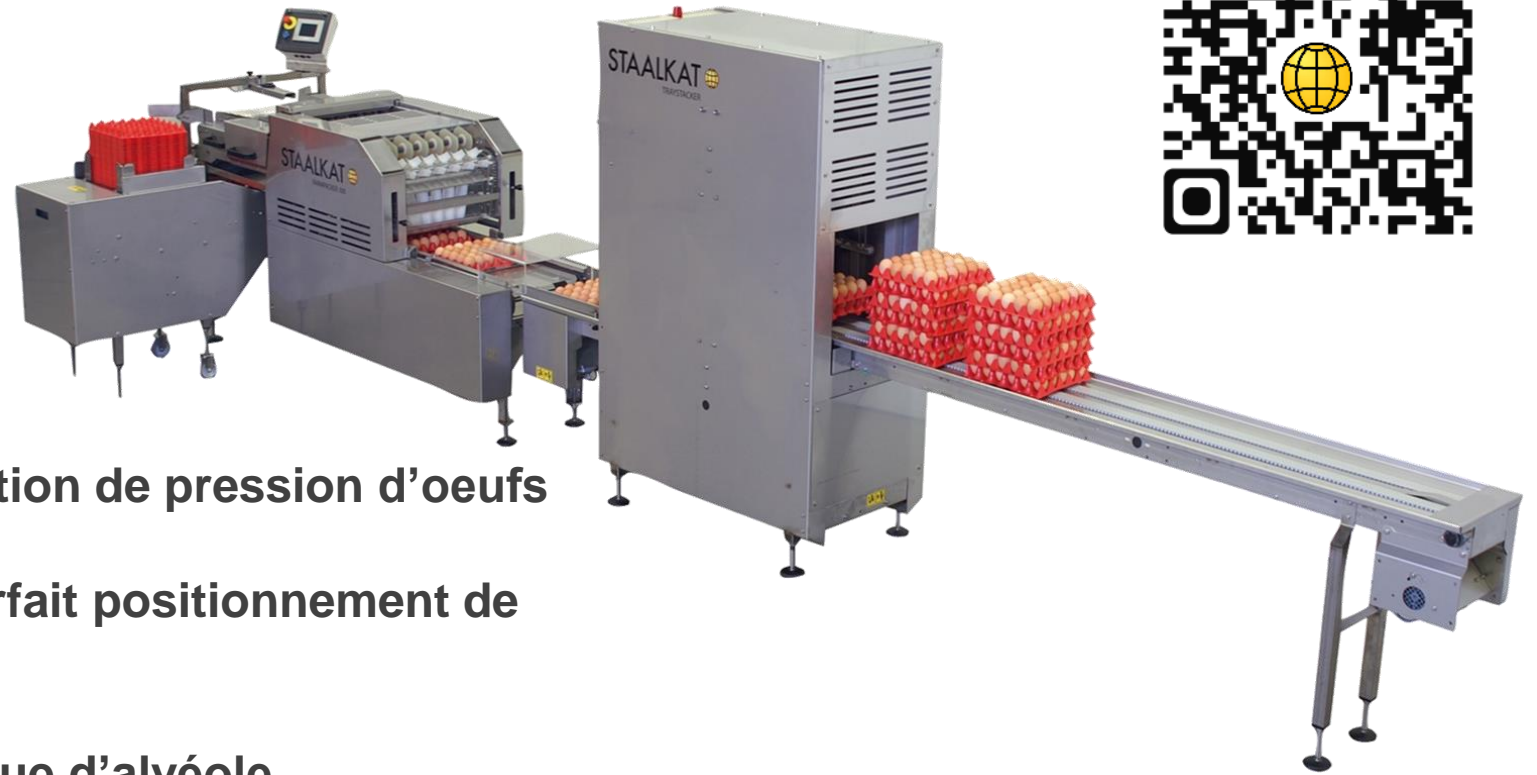

- Doseur avec détection de pression d'oeufs
- Trappe pour un parfait positionnement de l'alvéole
- Détection de manque d'alvéole
- Détection sortie empileur plein
- Sécurité sur les capots

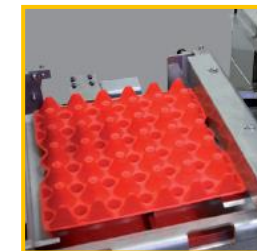
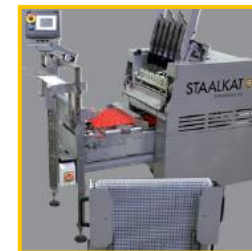

# SANOVO Farmpacker 100, Différents aménagements

## Models

- SFP100 A1
- SFP100 A2
- SFP100 A3
- SFP100 A4

- SFP100 SXA1
- SFP100 SXA2
- SFP100 SXA3
- SFP100 SXA4

To be introduced C/UL models

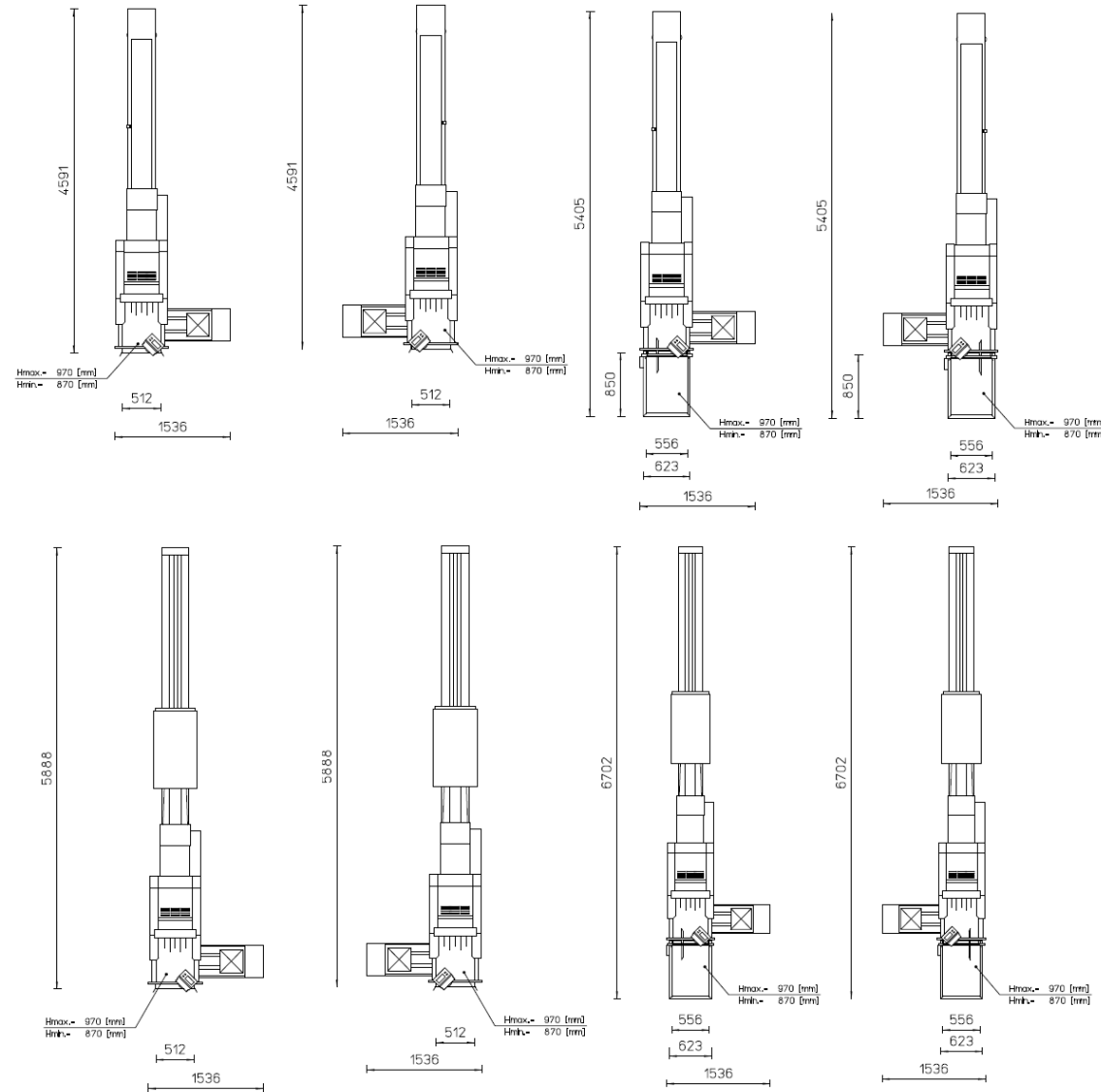

# SANOVO Farmpacker 200

72.000 oeufs/h, 200 caisses/h



*Capacité: 200 cph / 72.000 oeufs/heure*

*Alimentation: 230V+ terre*

*1 phase AC 50/60 Hz*

*Energie: 2,0 kVA*

*(2,2 kVA avec empileurs)*

## SANOVO Farmpacker 200 – Les points forts

- **Régulation de vitesse indépendante sur les 2 emballeuses**
- **Doseur avec contrôle de pression d'oeufs**
- **Trappe pour un parfait positionnement de l'alvéole**
- **Détection de manque d'alvéole**
- **Détection sortie empileur pleine**
- **Sécurités sur les capots**

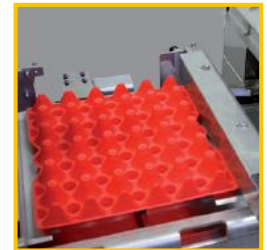

# SANOVO Farmpacker 24000

24.000 oeufs/h , 64 caisses/h





# SANOVO Farmpacker 24000 – Différents aménagements

## Models

- SFP24000 B1SX20
- SFP24000 B3SX20
- SFP24000 B1
- SFP24000 B3

- SFP24000 A1SX20
- SFP24000 A3SX20
- SFP24000 A1
- SFP24000 A3

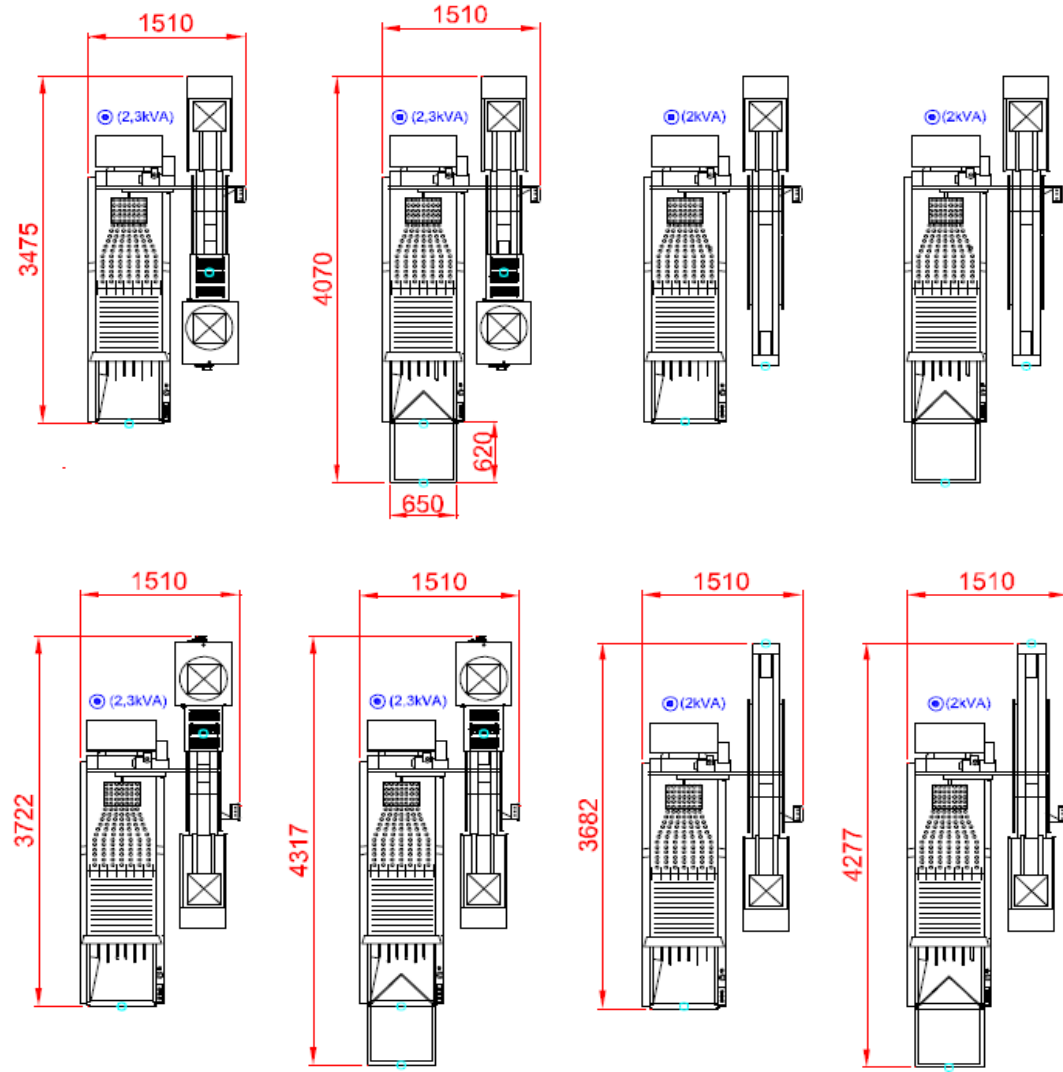

# SANOVO Farmpacker 24000 – Différents aménagements

## Models

- SFP24000 B2SX20
- SFP24000 B4SX20
- SFP24000 B2
- SFP24000 B4

- SFP24000 A2SX20
- SFP24000 A4SX20
- SFP24000 A2
- SFP24000 A4

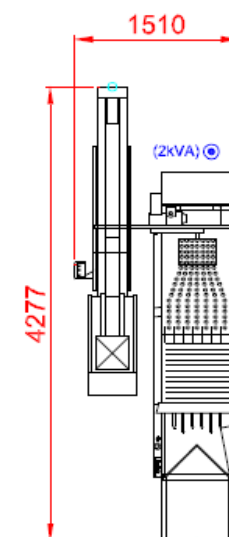
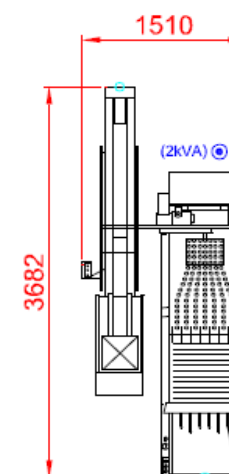
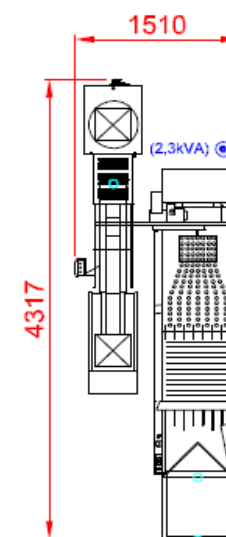
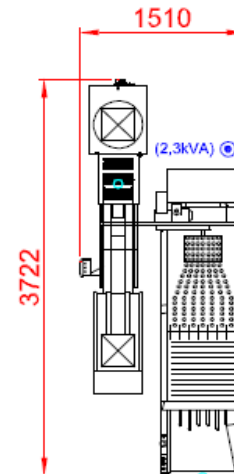
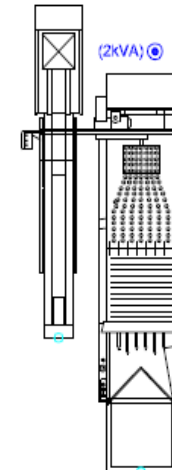
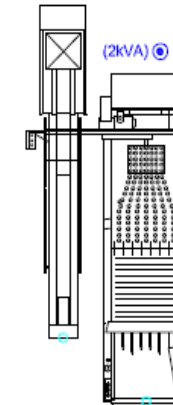
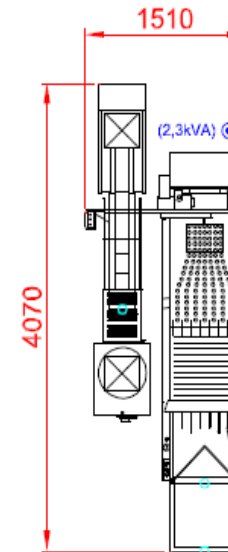
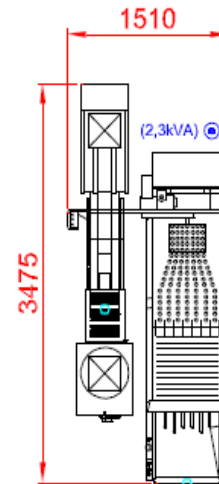

## SANOVO Farmpacker 24000, Les points forts

- 
- **En Inox avec un design et une sécurité de haute qualité**
  - **Faible coût d'entretien**
  - **Plus de 99.8% des pointes en bas**
  - **Manipulation des œufs en ventouses**

# SANOVO Empileur SX 20

**NOUVEAUTÉ**

- Empileur Tout Inox pour gagner du temps
- Ergonomique pour gagner du confort
- Compacte pour gagner de la place
- Adaptable sur FP 40 et FP 24 000



# SANOVO Empileur SX 20

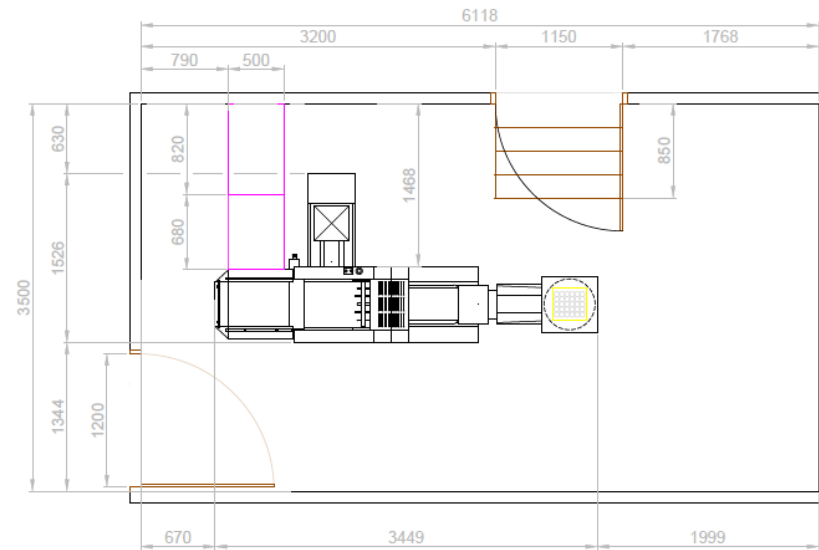
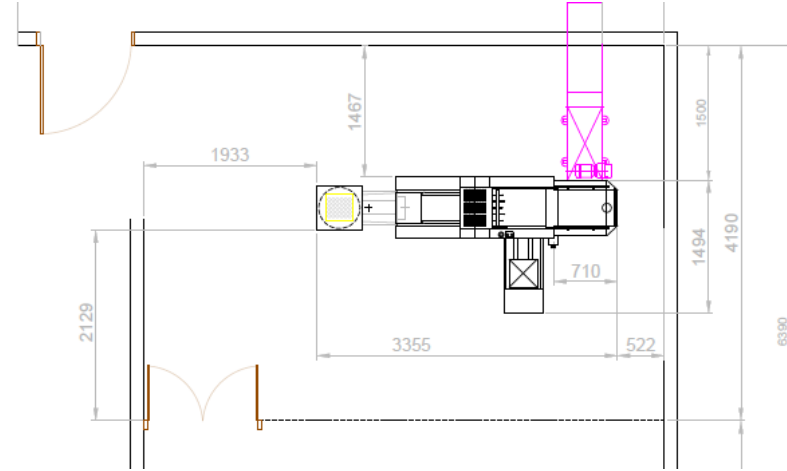
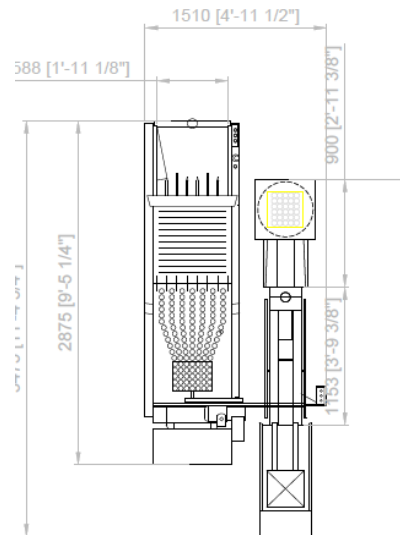
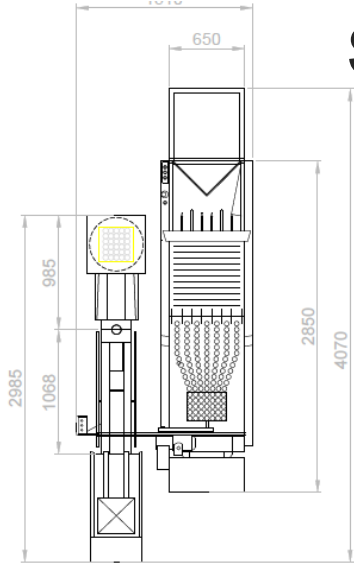

# Programme de garantie

*Farmpackers*

**2 ans pièces: Frais d'envoi inclus**

- **1<sup>ere</sup> année = standard**
- **2<sup>nd</sup> année après enregistrement sur internet**





# Les options et accessoires



# Imprimante NUOVO

## Jet d'encre

- Cartouches rechargeables
- On peut y inscrire ce que l'on veut
- Possibilité de travailler différentes références
- Système automatique.



## Système tampon

- Rechargeable
- Le moule du tampon n'est pas modifiable
- Si on veut travailler plusieurs références, il faut plusieurs tampons.
- En automatique ou manuel.

## ANT 5 Chargeur de Denester

- ▶ Alimente en continu le Denester
- ▶ Taille de stockage de 400 plateaux
- ▶ Commande simple
- ▶ Une espace d'1 m<sup>2</sup> suffit
- ▶ Plus de 3000 plateaux/h



## ANT 30 Palettiseur

80.000 Œufs/h

- Mise en palette automatique des alvéoles.
- Ergonomique, vrai confort de travail.
- Silencieux.
- Différents aménagements.
- Différentes options.





Retrouvez nous sur notre site [www.avyapy.fr](http://www.avyapy.fr)

# AVYAPY

*Le Perzo 56500 NAIZIN*



Official Distributor | **SANOVO**   
TECHNOLOGY GROUP